

Biomed. Lib.

HQ

751

P317s

1911

PEARSON --- SCOPE & IMPORTANCE TO THE STATE
OF THE SCIENCE OF NATIONAL EUGENICS 3RD EDITION



THE LIBRARY
OF
THE UNIVERSITY
OF CALIFORNIA
LOS ANGELES

GIFT

Dr. Emil Bogen

*The Scope and Importance to
the State of the Science of
National Eugenics*

BY

KARL PEARSON, F.R.S.

THIRD EDITION

LONDON

Published by the Cambridge University Press, Fetter Lane, E.C. 4

1911

PREFATORY NOTE TO SECOND EDITION

THIS lecture was originally delivered as the fourteenth Robert Boyle Lecture before the Oxford University Junior Science Club, on May 17, 1907. The first edition being out of print, the lecture is now reissued as No. I of a series of papers dealing in non-technical language with the problems of Eugenics.

The Staff of Galton Eugenics Laboratory has found the need of some introduction to the science of Eugenics, which shall place the purport of the investigations conducted there in a simple form before the general reader. This will be the aim of the present series of publications.

PREFATORY NOTE TO THIRD EDITION

THE fact that the earlier numbers of the Galton Laboratory Lecture Series are now out of print, shows that they have met a distinct demand, and justifies the present re-issue.

July, 1911.

[An authorized translation of this lecture has appeared in Germany, and a wholly unauthorized reprint in America.]

Bumel
HQ
751
P317A
1911

ON THE SCOPE AND IMPORTANCE TO THE STATE OF THE SCIENCE OF NATIONAL EUGENICS

IT needs more than a little boldness to suggest within the walls of one of our ancient universities that there is still another new science which calls for support and sympathy; nay, which in the near future will demand its endowments, its special laboratory, its technical library, its enthusiastic investigators and its proper share in the curriculum of academic studies.

The prestige of an ancient university does not wholly depend on the extent and novelty of the fields it cultivates, nor even on the external reputation of its doctors and masters. I remember my Savigny well enough to know that historically a university does not express the universality of the learning taught within its walls, but that the word emphasizes the corporate character of its masters and scholars. I also understand—with the experience of four universities behind me—not only the social, but the educational value of the traditional *universitas* of the Middle Ages; that common life of teacher and scholar which we now find preserved in broad outline, if in detail obscured, at two English universities alone.

As your guest to-day, even if I had the necessary knowledge, it would be ill-fitting to praise or to criticize modern Oxford. My intellectual debt to Oxford is too

great to make me an unbiased judge ; looking back on the stadia of intellectual growth from the days of the Oxford schoolmaster who taught me scientific method and a love of folklore in failing to teach me Greek grammar, the sign-posts are marked with Oxford names, whose moment to me must be a small part of what it formed to the mental life here. I note those : of Mark Pattison, from whom I learnt that the method of science is one with the method of true scholarship ; of Henry Nettleship, whose width of view in academic matters aided those of us who were struggling against prerogative and prejudice in London ; of York Powell, who taught me that a study of history is incomplete if it pass by the great biological factors which make for the rise and fall of nations ; of Raphael Weldon, whose life culminated in Oxford, and whose activity will, I trust, continue to bear fruit there,—of Weldon who taught us that biology is ripe for receiving aid from the exact sciences ; who, breaking down yet another barrier, emphasized the unity of logical method throughout the whole field of knowledge.

The calm, critical judgement of these men, their scorn, one and all, for the rhetorical, the superficial, the *idola* of the market-place, have built up my Gentile conception of Oxford and given me a not unwholesome fear of an Oxford audience. Their keen power of sympathy, however, their very intense, if much repressed national spirit—amounting to the truest form of patriotism—would, I believe and trust, have been not wholly withdrawn from me to-day in my endeavour to put before you the claims of this new science of mankind.

I do not demand your attention for this new field of inquiry because a university is expected to embrace

all sciences. On the contrary, I do it partly because I think the success of a university, as of an individual, depends largely on specialization in study. Now there is one form of technical education, which, although Oxford is too modest to give it a name, has yet been largely claimed for this University. I refer to the education of statesmen and administrators. There is need, I venture to hold, of a more conscious recognition of the existence of a school of statecraft, and that recognition must involve a fuller study of what can make and what can mar national life and racial character. We are told by a poet, who, understanding the spirit of his age, carefully balanced himself on the fence which separates the field of true insight from that of conterminous platitude, that 'the proper study of mankind is man'. But he has not helped us to see wherein this proper study of man consists. In all our universities there are branches of study which deal more or less directly with man. We have Philosophy with its discussions of man's mental processes, Ethics with the consideration of man's affections, passions, and conduct; Fichte, Hegel and other ethical philosophers have given us, here and there, luminous ideas, flash-lights on society and state. But has Philosophy, as such, taught us a single law by aid of which we can understand how a nation becomes physically or mentally more vigorous? Has it taught our statesmen to make their folk fitter for its task on the world-stage, or helped a race to meet a crisis in its history? We have had other branches of the science of man, measuring him, classifying him by his hair, by his skin, or by his skull. Yet Anthropometry and Craniometry, while piling up facts and figures, have done little to enable us to see wherein

human fitness for its functions really consists. Their professors disagree, much as do those of another branch of the study of man—Political Economy. What weight have Philosophy, Anthropology, or Political Economy at present in the field of statesmanship? Would the man who, rising in the House of Commons to-day, appealed to the laws of economic science, be even sure of a hearing? And if we turn to the study of History, surely more potent than these other branches in the aid it provides for the administrator, is not its lesson rather that of example and analogy than of true explanation and measurement of the causes of national evolution?

If the German people dominate to-day the French; if Japan rise like a mushroom, yet with the stability and the strength of the oak; if Spain and Holland disappear from the fore-rank of nations, can we throw light even for an instant on these momentous facts of history by such studies of mankind as are summed up in Philosophy, Anthropology, or Political Economy? I fear not. As instruments of education, as means of illustrating logical method, or of developing powers of healthy inquisitiveness and effective expression, they may be of value, in part indeed of unrivalled value. But as they stand at present they do not, alone or combined, form a technical education in statecraft.

And here I would like to make a fundamental distinction between what I understand by a technical education and a professional instruction. I do not believe that the university ought to busy itself in the least with the latter. It is taught most effectively in the barrister's chambers, in the architect's office, in the engineering workshop, in the government department, or in the hospital ward. The tendency nowadays to

replace apprenticeship by professional instruction in college or university is a fatal one. The academic purpose should be concentrated on the development of the mind as an instrument of thought. It may do this by aid of philosophy, or by aid of language, or by aid of science; but it cannot do it by any form of purely professional instruction. By technical education I mean something very different from an instruction in the facts, formulae, and usages of a profession. It consists, I hold, not in learning an art, but in developing the mind by studying that branch of science which must lie at the basis of each profession. The theory of Elasticity is as potent an instrument for mental discipline if we illustrate it on bridge-structure, as if we confined our attention to metal spels and snips of pianoforte wire in the physical laboratory. The science of Medicine—think for a moment even of such points as immunity, incubation, and crisis—affords material for reasoned observation and leads to a mental alertness, which may be equalled but cannot be excelled in any other branch of biological inquiry. The true test of all technical education lies in whether we can answer in the affirmative the question: Does it provide adequate mental training for the man who has no intention of following a profession? If we can, then, and then only, may we assert that it is a fit subject for academic study.

By a superficial knowledge of many things, we break all continuity in education; we may reach a 'top-dressing', but the subsoil has never been turned and cultivated. From this standpoint, academic education will, I feel certain, grow more and more technical education; the man who has exercised his mind in thoroughly examining one small field of knowledge,

who has seen its solved and unsolved problems, and who has tried his own powers in even some little bit of pioneer work, has received a training which will stand him in good stead, whatever he may afterwards turn his mind to in life. I can conceive a great university for the training of Mind, in which the whole teaching force should be devoted to the manufacture of problems, calculated to exercise and develop the youthful mind, without any regard to their bearing on real knowledge. Such was very nearly the system of the Cambridge Mathematical School of a generation ago. It produced splendid lawyers, subtle theologians, and a few ardent students of science. But the labour expended in the manufacture of problems, the sole purpose of which was to provide material for mental gymnastics, might have achieved European reputation for the manufacturers had it been devoted to the pressing problems of technical science. It is because every university has a duty in the creation of new knowledge, as well as a duty in education, that it seems desirable that our mental training should take as its problems those which are actually demanding solution in practical life.

If we are to have a school of statecraft, I venture to suggest that a special technical education shall be developed for it. We must not be content with the mental gymnastics which can be provided by philosophy or political history. We must add that study of the biological factors which York Powell saw was so needful to historical investigation. We must approach with the detached mind and calm criticism of Mark Pattison those problems as to the rate of change of races, a knowledge of which Raphael Weldon has told us is

'the only legitimate basis for speculations as to their past history and future fate'.

If we attempt to define the scope of statecraft we enter no doubt the field of controversy, but may we not extend the condition which so fitly expresses the primary need of the individual—the healthy mind in healthy body—to the swarm of individuals with which the statesman has to deal? Taking the word 'sanity' in its broadest sense of health and soundness, the primary purpose of statecraft is to insure that the nation as a whole shall possess sanity; it must be sound in body and sound in mind. This is the bedrock on which alone a great nation can be built up; by aid of this sanity alone an empire once founded can be preserved. There are secondary important conditions—too often regarded as primary—which are undoubted parts of statecraft. The nation must have the instruments and the training needful to protect itself and its enterprises; it must hold the sources of raw material and the trade routes requisite to develop the wealth upon which its population depends; it must have the education necessary to make its craftsmen, its traders, its inventors, its men of science, its diplomatists, and its statesmen the equals at least of those of its rivals on the world-stage. Nay, perhaps as important as all these, it must have traditions and ideals so strong that the prejudices of individuals and the prerogatives of classes will fall before urgent national needs; it requires teachers, be they pressmen, poets, or politicians, who grasp the wants of the nation as a whole; who, independent of class and party, can remind the people at the fitting moment of their traditions, and their special function amid nations.

Yet if we come to analyse these secondary conditions, we shall find in each case that their realization depends on the fulfilment of our primary condition. Without high average soundness of body and soundness of mind, a nation can neither be built up nor an empire preserved. Permanence and dominance in the world passes to and from nations even with their rise and fall in mental and bodily fitness. No success will attend our attempts to understand past history, to cast light on present racial changes, or to predict future development, if we leave out of account the biological factors. Statistics as to the prevalence of disease in the army of a defeated nation may tell us more than any dissertation on the genius of the commanders and the cleverness of the statesmen of its victorious foe. Lost provinces and a generation of hectoring may follow to the conquered nation whose leaders have forgotten the primary essential of national soundness in body and mind.

Francis Galton, in establishing a laboratory for the study of National Eugenics in the University of London, has defined this new science as 'the study of agencies under social control that may improve or impair the racial qualities of future generations, either physically or mentally'. The word *eugenic* here has the double sense of the English *wellbred*, goodness of nature and goodness of nurture. Our science does not propose to confine its attention to problems of inheritance only, but to deal also with problems of environment and of nurture. It may be said that much social labour has already been spent on investigating the condition of the people; there have been Royal Commissions, Parliamentary and Departmental Committees, and much independent effort on the part of philanthropists, medical

men, and social reformers. I would admit all this, and would try to appraise it at its true value. Some of it has provided useful material for eugenic study; much of it is the product of wholly irresponsible witnesses with comments by commissioners equally untrained in dealing with statistical problems. Witnesses, commissioners, philanthropists, social reformers, as a rule, and medical men only too frequently, sadly need that technical education, that power of reasoning about statistical data, which I think will become general when Eugenics has been made a subject of academic study, and minds specially trained to this branch of scientific inquiry are placed at the disposal of our statesmen. I do not, of course, say that there was no eugenic research before Francis Galton invented the word and named the new science. But I believe the day not distant when we shall recognize that he seized the psychological moment to assert its claim to academic consideration; and that in the time to come the nation will be more than grateful to the man who said that the university is the true field for the study of those agencies which may improve or impair our racial qualities. To become a true science, you must remove our study from the strife of parties, from the conflict of creeds, from false notions of charity, or the unbalanced impulses of sentiment. You must treat it with the observational caution and critical spirit that you give to other branches of biology. And when you have discovered its principles and deduced its laws, then, and then only, you can question how far they are consonant with current moral ideas or with prevailing human sentiment. I myself look forward to a future when a wholly new view as to patriotism will be

accepted ; when the individual will recognize more fully and more clearly the conflict between individual interests and national duties. I foresee a time when the welfare of the nation will form a more conspicuous factor in conduct ; when conscious race-culture will cope with the ills which arise when we suspend the full purifying force of natural selection ; and when charity will not be haphazard—the request for it being either a social right, or the granting of it an anti-social wrong. But if we are to build up a strong nation, sound in mind and body, we shall have to work in the future with trained insight : I feel convinced that real enlightenment will only follow a scientific treatment of the biological factors in race development.

There is an element of danger in the study of Eugenics, which I would not have you overlook. If the attention be fixed on the factors which make for deterioration ; if we spend our days over statistics of the insane, the mentally defective, the criminal, the tuberculous, the blind, the deaf, and the diseased, the inevitableness of it all is apt to reduce us to the lowest depths of depression. But this is only one side of the picture ; the inevitableness is just as marked when we come to deal with health and strength, with ability and intelligence. If the iniquity of the fathers be visited upon the children to the third and fourth generation—assuredly so is their virtue. If this needs emphasis, study the two pedigrees I put before you. In Fig. I we have the pedigree of a family in which eccentricity, insanity, and phthisis have recurred generation by generation—associated occasionally with great ability. A general ‘want of mental balance’ is the peculiar mark of the stock. In Fig. II we have the pedigree of a family in which

FIG. 1

Pedigree Of Stock Possessing Want Of Mental Balance

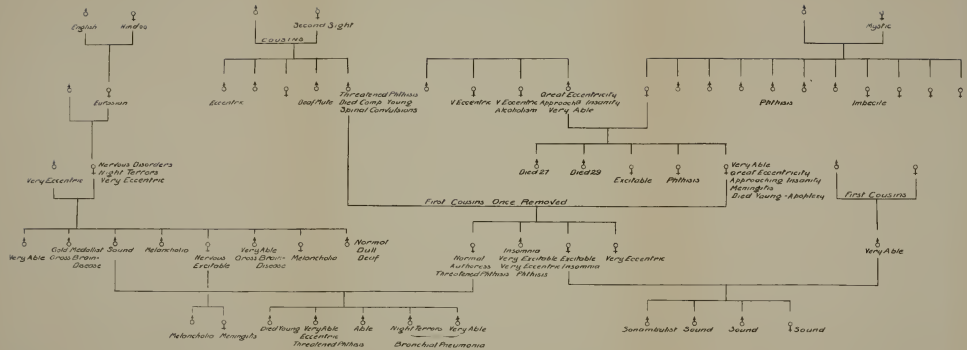

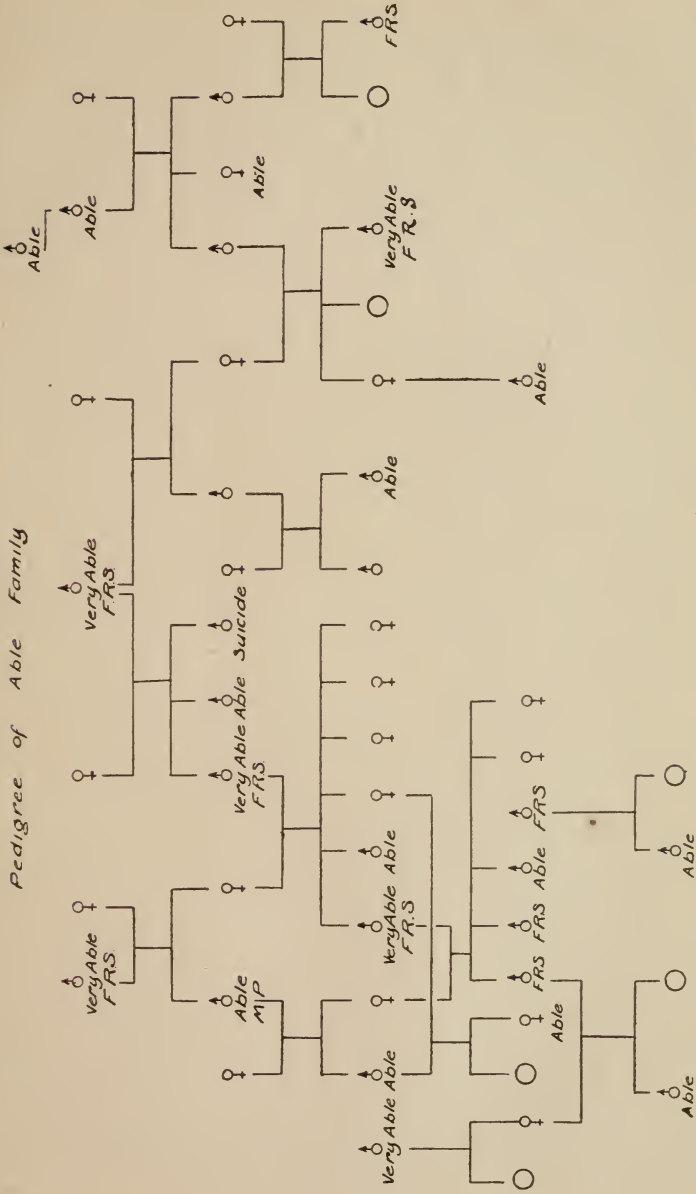

FIG. II.

extreme ability not correlated with such want of mental balance has descended through five generations.

Yet apart from this, to the true man of science, nothing is impure or repulsive. His mission is to study all phases of life; and in the case before us to determine their relation to national fitness and racial degeneracy. I cannot put it better than in the words of Francis Bacon:—

‘But for unpolite or even sordid particulars which, as Pliny observes, require an apology for being mentioned, even these ought to be received into natural history, no less than the most rich and delicate; for, natural history is not defiled by them any more than the sun, by shining alike on the palace and the privy; and we do not endeavour to build a capitol or erect a pyramid to the glory of mankind, but to found a temple in imitation of the world, and consecrate it to the human understanding, so that we must frame our model accordingly; for whatever is worthy of existence is worthy of our knowledge; but ignoble things exist as well as the noble.’

Those who have not the courage, or it may be the strength to face life as it is, must avoid Science; or at least the portion of it termed National Eugenics. Those who fear to know humanity in its degradation, as well as in its nobler phases, will scarce reach the standpoint of knowledge from which they can effectively help the progress of our race. They will be ignorant of the essential factors which alone can determine whether a nation shall be sound in mind and body. Disease and Health, Vigour and Impotence, Intelligence and Stupidity, Sanity and Insanity, Conscientiousness and Irresponsibility, Clean Living and Licence,—all things which make for both strength and weakness of character—must be studied, not by verbal argument, but be dissected

under the statistical microscope, if we are to realize why nations rise and fall, if we are to know whether our own folk is progressing or regressing. Only by such examination can we understand the disease; only by such means can we suggest a valid cure where we find there is that in any community which is making for degeneracy. The study of Eugenics centres round the actuarial treatment of human society in all its phases, healthy and morbid.

In every branch of science there exist, I believe, three chief stages of development. These stages are not always completely differentiated, and forms of the earlier stages may usefully survive into the later periods.

The first stage is the *Ideological*. Men have formed ideas about phenomena on the basis of very limited experience. They spend their time and energy in discussing these ideas without much reference to the phenomena themselves. This discussion of ideas—this wrangling over definitions—is not idle. It not only led in mediæval times to a philosophy which gave a by no means contemptible educational training; but in some of the most developed forms of science, as in the foundations of our most advanced pure mathematics, ideology can again do work of the greatest service. It corresponds to the pre-Baconian state of most sciences.

The second stage is the *Observational*. It is a reaction against the purely introspective attempt at a natural philosophy. It consists in observing phenomena critically, and recording and describing their sequences. It is a fundamental stage towards any really scientific theory of nature. It will always remain a large factor in scientific work. But while it needs the mind of special width and creative power to invent a reasonable

theory, and demonstrate it by the right type of observation, it is possible for the average man to observe carefully and to go on observing through a long lifetime. The result is the accumulation for decades and decades of observations made with little idea of testing a definite theory of organic or inorganic nature. These observations form a large proportion of scientific literature; and, I fear, are not always of service when the creative scientist desires to test his theories. The time spent in hunting up data, which may after all fail to give the special small detail requisite, would often have sufficed to produce more adequate observations made *ad hoc*. Hence I think there will be, if there be not already, a reaction against purely observational or descriptive science.

The third stage in all science is the *Metrical*. We proceed from observation to measurement, to accurate numerical expression of the sequences involved. It has been more than once asserted that by quantitative analysis you cannot obtain more than lies in the data from which you start. The statement is either merely platitude; or else, if more than idle, it is false. The object of analysis is *not* to obtain more from data than exists therein; but to find out what actually does exist therein; and that is usually far from obvious to untrained inspection. The actual positions of the moon can be observed and recorded day by day. Such are the data. Shall we assert that Lunar Theory as it exists to-day—the product of nearly two and a half centuries of work by some of the finest mathematical intellects—contains no more than the data from which it started? I think we may leave such an attitude to those who do not grasp that the highest aim of science is not the presentation

of facts, but the regulating of a world of conceptions, by aid of which we can mentally describe those facts. From the data themselves we have to determine whether this 'statuting of mind' is legitimate within the limits of our observations. 'Analysis cannot get more out of the data than is already in them,' cries the biologist. On the contrary, having added to the data *mind*, the combination provides a great deal that had no previous existence. Even Huxley could write: 'Mathematics may be compared to a mill of exquisite workmanship, which grinds your stuff to any degree of fineness, but nevertheless what you get out depends on what you put in; and as the grandest mill in the world will not extract wheat-flour from peascods, so pages of formulae will not get a definite result out of loose data.'

On the contrary, I assert that our modern mathematical methods reach a perfectly definite result when applied to such data; they measure the deviation, the differentiation of pease-meal from wheat-flour; that is to say, they determine quantitatively the exact degree of looseness in the data themselves. Is it fear of discovering the exact degree of looseness in their own data, which leads some votaries of descriptive science to belittle metrical investigations?

Nay, I do not hesitate to assert that any branch of science, until it reaches its third or metrical stage of development, is incomplete and fails to provide the highest mental training possible. There are few departments of scientific investigation which provide so thoroughly for discipline in all the three branches of science, the ideological, the observational, and the metrical, as biology; this is particularly true of its applications to man. What better training in ideology than a study

of the theory of the state from Plato, through Aristotle and Hobbes till we reach, in Comte, the view that the science of society is impossible without biology? What fitter training in observation than the biologist provides, when he teaches us experimentally the facts of inheritance and the influences of environment? What more precise exercise for the mind than the actuarial appreciation of these biological factors 'as agencies which improve or impair the racial qualities of future generations'?

Here, I firmly believe, is in broad outline the scheme necessary to form a school of statecraft. The mind must be led through each of the ascending stages of science—till it is able to measure accurately and to describe in fitting words those fundamental biological factors on which the progression and the debasement of human societies alike depend.

But you may ask me if I am not painting a science of the future; if I am not merely repeating the vague words of the old sociologists, from Comte to Herbert Spencer? Where is the material, what are the methods, how definite are the deductions of this new science of Eugenics?

First then: where is the material?

I reply that every large school and university in this country can provide physical and psychical material for the student of Eugenics if he will set to work and observe. Every medical officer in asylum and hospital is in charge of a great Eugenics Laboratory if he would only realize it. And many indeed are realizing it. Quite recently between 300 and 400 pedigrees of tuberculous stock; 400 family histories of insanity; 400 descriptions of parentage and home environment of

mentally defective children, with as many of normal children from one district, and upwards of 1,000 from a second district, have reached the Eugenics Laboratory in London. If this seem to lay all stress on the abnormal and defective side, I may add that the Laboratory possesses records of nearly 400 noteworthy families—a part of which have been published—and that I have completed now a series of nearly 500 normal family histories, many of them containing 50 to 100 individuals, with psychical and physical descriptions and entries as to ailments and causes of death. These are but, of course, the beginnings of a collection which one hopes and trusts will one day represent large samples of the physique, the mentality, the fertility, and the disease of wide classes of the nation. The success of this sort of Eugenics Laboratory collection depends upon spreading widely three convictions: (i) that really useful results have flown, and will flow, from contributing to it; (ii) that individuals, if appealed to frankly, will frankly tell the truth that lies within their knowledge; and (iii) that the individual becomes a non-identifiable statistical unit [before the record passes into the hands of the computer].¹

Beyond the special collections of an individual laboratory there is already available a fair amount of published material. The United States have issued special censuses of the blind and of deaf-mutes. The Edinburgh Charity Organization Society has issued an excellent memoir on the home environment and the physique of 700 to 800 school children; above all, there are the

¹ The Eugenics Laboratory will gladly forward schedules (i) for general family history or (ii) for special family abnormalities to any one interested in Eugenic inquiry and willing to aid by filling in and *returning* them.

Registrar-General's Annual Reports, the Censuses, the Reports of Fever Hospitals, of Lunacy Commissioners, and of the Medical Officers of Asylums. Of some, but less value, are the Reports of Government Commissions and the works of energetic, but statistically untrained, philanthropists like Charles Booth and Seebohm Rowntree. Important special researches, like that of Mr. Tocher on the insane of Scotland, or that now being carried out by Dr. Goring on the convicts in His Majesty's Prisons, serve to increase the total data already available or nearly so. While all Eugenics workers crave for more material, and for better quality of material, yet there already exists ample material upon which to base the beginnings for our science.

If we turn from material to method, we note that except in as far as results for animals have application to man, we cannot experiment on individuals, and our methods must therefore be those applicable to mass-observations—that is to say, those actuarial methods applied to biological data which we now term the methods of biometry. It is not needful for me to enlarge now or here on these methods. Suffice it to say that they appear to measure effectively the relationship between factors which are not causally linked together. For the explanation of what follows I would state that the arithmetical value of a certain quantity—the so-called coefficient of correlation—is chiefly used to measure this relationship. Starting when the quantities are absolutely independent with zero value, it rises with their complete causal relationship to unity. Table I shows the sort of values taken by this coefficient for various kinds of association, when the variates lack the absolute dependence of pure causation.

From method I turn finally to illustrate the nature of the conclusions which have already been reached by Eugenic inquiry. As a preliminary, I must picture for you what I think evolution means in the case of human societies.

TABLE I. CORRELATION COEFFICIENTS

HIGH CORRELATION .1 TO .75.	
Right and left femur in man98
Finger and forearm in man85
Foot and forearm in man80
Middle phalanges of middle and little finger76
CONSIDERABLE CORRELATION .75 TO .5.	
Weight and stature in women72
Finger and stature in man66
Vaccination and recovery in cases of small-pox60
Weight and strength of pull in man55
MODERATE CORRELATION .5 TO .25.	
Forearms of two brothers49
Deviations in bank reserve and discount rate37
Coat colour in horse and its grandsire30
High barometer in Portugal and low barometer in Norway27
LOW CORRELATION .25 TO .00.	
Resemblance of Aphis to its grandmother24
Size of family, mother and daughter21
Duration of lives, mother and daughter15
Length and breadth of Parisian skulls05

There was a time when, thinking over the marvellous intellectual, artistic, and physical development of ancient Greece, I could wonder how still more ample it might have been had there existed a master spirit or an imperious motive to weld those statelets into one great nation and check the rarely ceasing internal wars and personal feuds. Looking back—from what some of you may consider a less ethical, but I believe a more scientific standpoint—I now see a direct association between the achievements of Greece and the intensity of its intertribal struggles. The *pax romana* did not provide the Greek spirit with an atmosphere as bracing

to either bodily or spiritual development, as the instability and storm which accompanied the earlier conditions.

The struggle of man against man, with its victory to the tougher and more crafty: the struggle of tribe against tribe, with its defeat for the less socially organized: the contest of nation with nation whether in trade or in war, with the mastery for the foreseeing nation, for the nation with the cleaner bill of health, the more united purpose of its classes, and the sounder intellectual equipment of its units: are not these only phases of the struggle for existence, the factors which have made for human progress, which have developed man from brute into sentient being? We have been told that 'the cosmic process is opposed to the ethical'! But from the standpoint of science, is not the ethical the outcome of the cosmic? Are not the physique, the intellectuality, the morality of man, the product of that grim warfare between individual and individual, between society and society, and between humanity and nature, of which we even yet see no end? The ethical as the product of the cosmic process will indeed aid us when we pass outside the field of science. But standing well within the boundaries of that field, are men to cry like little children because the world is not 'as it ought to be'?

Nach ewigen ehernen
Grossen Gesetzen
Müssen wir alle
Unseres Daseyns
Kreise vollenden.

Nay, what has been rather man's method in mastering the physical universe? Has he not studied those brazen

eternal laws, and guided the course of his being by that knowledge? Realize that the most valuable part of that knowledge is scarcely two hundred years old. And when we turn to biology—to the biological factors which control man's life and its relations to that of other organisms—are we not yet at the very dawn of discovery,—a dawn whose actual storm-drifts foretell the coming flood of light?

Plato, in the Fifth Book of the *Laws*, describes what he terms a purification or purgation of the state. Permit me for my weakness, not yours, to cite it from Jowett's translation:—

'The shepherd or herdsman, or breeder of horses, or the like, when he has received his animals will not begin to train them until he has first purified them in a manner which befits a community of animals; he will divide the healthy and unhealthy, and the good breed and the bad breed, and will send away the unhealthy and badly bred to other herds, and tend the rest, reflecting that his labours will be vain and without effect, either on the souls or bodies of those whom nature and ill-nurture have corrupted, and that they will involve in destruction the pure and healthy nature and being of every other animal, if he neglect to purge them away. Now, the case of other animals is not so important:—they are only worth mentioning for the sake of illustration, but what relates to man is of the highest importance; and the legislator should make inquiries, and indicate what is proper for each in the way of purification and of any other procedure. Take, for example, the purification of a city—there are many kinds of purification, some easier and others more difficult; and some of them, and the best and most difficult of them, the legislator, if he be also a despot, may be able to effect; but he who, without a despotism, sets up a new government and laws, even if he attempt the mildest of purgations, may think himself happy if he can complete the work. The best kind of purifica-

tion is painful, like similar cures in medicine, involving righteous punishment or inflicting death or exile in the last resort. For in this way we commonly dispose of great sinners who are incurable, and are the greatest injury to the whole state. But the milder form of purification is as follows: when men who have nothing, and are in want of food, show a disposition to follow their leaders in an attack on the property of the prosperous—these, who are the natural plague of the state, are sent away by the legislator in a friendly spirit as far as he is able, and this dismissal of them is euphemistically termed a colony. And every legislator should contrive to do this at once.'

Now may we not claim Plato as a precursor of the modern Eugenics movement? He grasped the intensity of inheritance, for he appeals to the herd and the flock; he realized the danger to the state of a growing band of degenerates, and he called upon the legislator to purify the state. Plato's purgation, if you will accept the view I have endeavoured to lay before you to-day, has in fact hitherto been carried out by natural selection, by the struggle of man against man, of man against nature, and of state against state. This very cosmical process has so developed our ethical feelings, that we find it difficult to regard the process as benign. A hundred years ago we still hung the greater proportion of our criminals or sent them for life across the seas, not even euphemistically terming it a 'colony'. We shut up our insane, making no attempt at cure; the modern system of hospitals and institutions and charities was scarcely developed; the physically and mentally weak had small chance of surviving and bearing offspring. There was a constant stern selection purifying in Plato's sense the state. The growth of human sympathy—and is not this one of the chief factors of national fitness?—has been so

rapid during the century that it has cried Halt! to almost every form of racial purification. Is not this the real opposition which Huxley noticed between the ethical and cosmic processes? One factor—absolutely needful for race survival—sympathy, has been developed in such an exaggerated form that we are in danger, by suspending selection, of lessening the effect of those other factors which automatically purge the state of the degenerates in body and mind.

Do I therefore call for less human sympathy, for more limited charity, and for sterner treatment of the weak? Not for a moment; we cannot go backwards a single step in the evolution of human feeling! But I demand that all sympathy and charity shall be organized and guided into paths where they will promote racial efficiency, and not lead us straight towards national shipwreck. The time is coming when we must consciously carry out that purification of the state and race which has hitherto been the work of the unconscious cosmic process. The higher patriotism and the pride of race must come to our aid in stemming deterioration; the science of Eugenics has not only to furnish Plato's legislator with the facts upon which he can take action, but it has to educate public opinion until without a despotism he may attempt even the mildest purgation. To produce a nation healthy alike in mind and body must become a fixed idea—one of almost religious intensity, as Francis Galton has expressed it—in the minds of the intellectual oligarchy, which after all sways the masses and their political leaders.

Let me put before you a little more in detail the biological aspects of national growth. The Darwinian hypothesis asserts that the sounder individual has more

chance of surviving in the contest with physical and organic environment. It is therefore better able to produce and rear offspring, which in their turn inherit its advantageous characters. Profitable variations are thus seized on by natural selection, and perpetuated by heredity.

Now if we are to apply these biological ideas to the case of man, we must have evidence (i) that man varies, (ii) that these variations, favourable or unfavourable, are inherited, and (iii) that they are selected.

Is it needful now to show that man varies? We not only know he varies, but the extent of variation in both man and woman has been measured by the Biometric School in nearly two hundred cases. The variability within any single local race of man amounts from 4 or 5 to 15 or 20 per cent. of the absolute value of the character.

Secondly, are these variations inherited? Of this there is not the slightest doubt. They are not mere somatic fluctuations, but correspond to real geminal differences. The problem of inheritance is closely associated with that of the resemblance of members of the same stock, due caution being paid to the possibilities of environmental influence. Now we may separate the characters in which we are at present interested into three: (*a*) the Physical, (*b*) the Pathological, and (*c*) the Psychological.

Table II gives us the resemblance between parent and offspring for a number of physical characters in man. Please note that the coefficient recorded is zero if there be no relationship and unity, if parent and offspring show an invariable relationship in the character under discussion. We see that the resemblance in the case of

man lies between .4 and .5. It is about half-way up the correlation scale. Again the lower part of Table II gives us corresponding measures of resemblance between brethren for like characters, we notice that the resemblance lies between .5 and .6.

TABLE II. INHERITANCE OF PHYSIQUE
PATERNAL INHERITANCE. MALES ONLY.

<i>Method.</i>	<i>Authority.</i>	<i>Ages.</i>	<i>Intensity.</i>
Family Measurements :			
Stature	Pearson and Lee	Adults	.51
Span	" "	"	.45
Forearm	" "	"	.42
Family Records :			
Eye Colour	" "	"	.55

FRATERNAL INHERITANCE.

Family Measurements :			
Stature	Pearson and Lee	Adults	.51
Span	" "	"	.55
Forearm	" "	"	.49
Family Records :			
Eye Colour	" "	"	.52
School Observations :			
Eye Colour	Pearson	Boy and Boy	.54
School Measurements ¹ :			
Head Breadth	"	" "	.59
Head Length	"	" "	.50
Head Height	"	" "	.55
Cephalic Index	"	" "	.49

Mean Paternal Value .48. Mean Fraternal Value .53.

For both parental and fraternal inheritance in man we find for physical characters much the same values as we find in the cases of cattle, horses, and dogs. This is illustrated in Table III.

Turning now to diseased or pathological cases, we have at present only three types that have been dealt

¹ Reduced to standard age of twelve years.

with. These are Mr. Edgar Schuster's results for the inheritance of deaf-mutism, Mr. Heron's results for the inheritance of the insane diathesis, and my own work on pulmonary tuberculosis. It is worth noting that these results are all first-fruits of Mr. Galton's foundation of a Eugenics Laboratory.

TABLE III. PARENTAL INHERITANCE IN DIFFERENT SPECIES

<i>Species.</i>	<i>Character.</i>	<i>Mean Value.</i>	<i>No. of pairs used.</i>
Man	Stature	.51	4,886
	Span	.48	4,873
	Forearm	.42	4,866
	Eye Colour	.50	4,000
Horse	Coat Colour	.52	4,350
Basset Hound . . .	Coat Colour	.52	823
Greyhound	Coat Colour	.51	9,279
Aphis	{ Right Antenna	.44	368
	{ Frontal Breadth		
Daphnia	{ Protopodite	.47	96
	{ Body Length		
Mean	—	.48	

TABLE IV. PATHOLOGICAL INHERITANCE

<i>Condition.</i>	<i>Investigator.</i>	<i>Parental.</i>	<i>Fraternal.</i>
Deaf-mutism	Schuster	.54	.73
Insanity	Heron	.58	.48
Pulmonary Tuberculosis	Pearson	.50	.48
Mean Value	—	.54	.56

Now it must be admitted at once that these diseased states are far harder to deal with than simple quantitative characters. Their treatment involves more assumptions, and the data are less trustworthy. But from what

TABLE V. SCHOOL OBSERVATIONS

RESEMBLANCE OF SIBLINGS,¹

Psychical Characters.

<i>Character.</i>	<i>Boys.</i>	<i>Girls.</i>	<i>Boy and Girl.</i>
Health52	.51	.57
Eye Colour54	.52	.53
Hair Colour62	.56	.55
Curliness52	.52	.52
Cephalic Index49	.54	.43
Head Length50	.43	.46
Head Breadth59	.62	.54
Head Height55	.52	.49
Mean54	.53	.51

TABLE VI. SCHOOL OBSERVATIONS

RESEMBLANCE OF SIBLINGS

Psychical Characters.

<i>Character.</i>	<i>Boys.</i>	<i>Girls.</i>	<i>Boy and Girl.</i>
Vivacity47	.43	.49
Assertiveness53	.44	.52
Introspection59	.47	.63
Popularity50	.57	.49
Conscientiousness59	.64	.63
Temper51	.49	.51
Ability46	.47	.44
Handwriting53	.56	.48
Mean52	.51	.52

¹ The term 'sibling' is used for the offspring of the same pair without regard to sex.

I show in this table I think we may safely draw two conclusions: (a) the tendency to diseases of mind and body is inherited, (b) this inheritance may be slightly greater, it is hardly likely to be less, than the inheritance of quantitatively measurable physical characters.

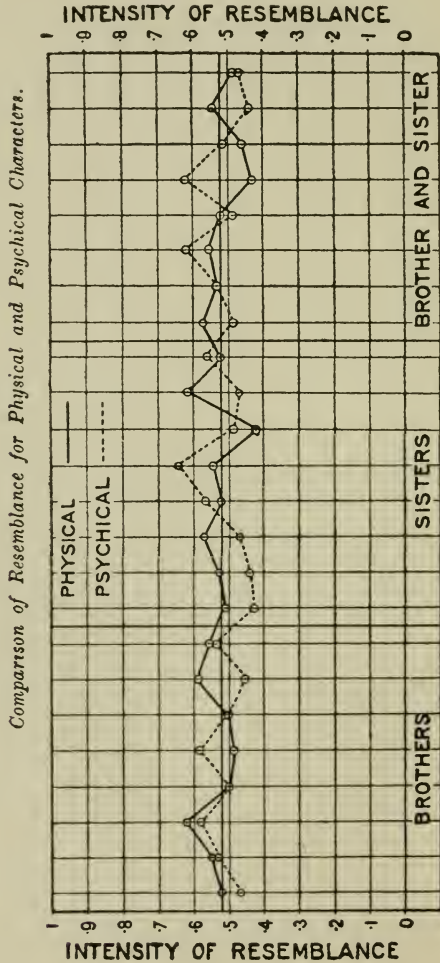

I now turn to the inheritance of the psychical characters. Here again we tread on more difficult ground. On first investigating the problem myself I worked with school children, and for the following reasons. The teacher compares the individual with his general experience of many children; he thus approaches much more nearly an absolute standard than if we ask for an isolated return as to a single family from this or that relatively inexperienced recorder. Secondly, it is not often that we can find any data of the psychical characters of father and son taken at about the same period in life. If you will look at Tables V and VI and Fig. III you will see that I have not been able to discover any difference in intensity of inheritance between the psychical and physical characters in children.¹ Mr. Schuster has been able to get over my difficulty at least for one character,

TABLE VII. INHERITANCE OF ABILITY. MALE AND MALE PATERNAL INHERITANCE.

<i>Method.</i>	<i>Authority.</i>	<i>Ages.</i>	<i>Intensity.</i>
Oxford Class Lists	Schuster	Adults	.49
Family Records	Pearson	Adults	.58

FRATERNAL INHERITANCE.

Oxford Class Lists	Schuster	Adults	.56
Family Records	Pearson	Adults	.54
School Class Lists	Schuster	Boys	.56
School Observations	Pearson	Boy and Boy	.52

Mean Paternal Value .54. Mean Fraternal Value .54.

¹ The tables reproduced here are drawn from my Huxley Lecture or other biometric memoirs.

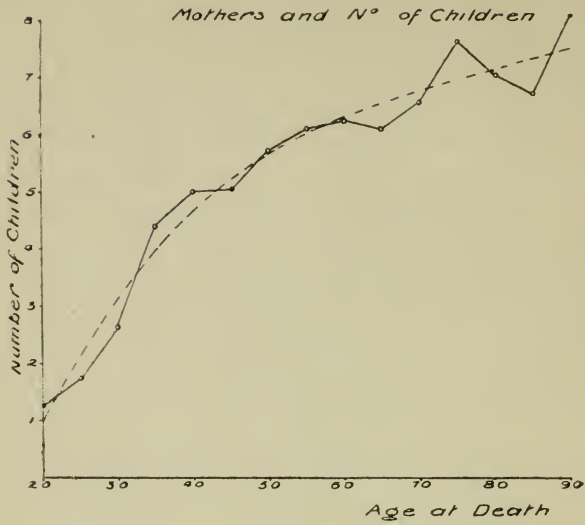

FIG. IV.

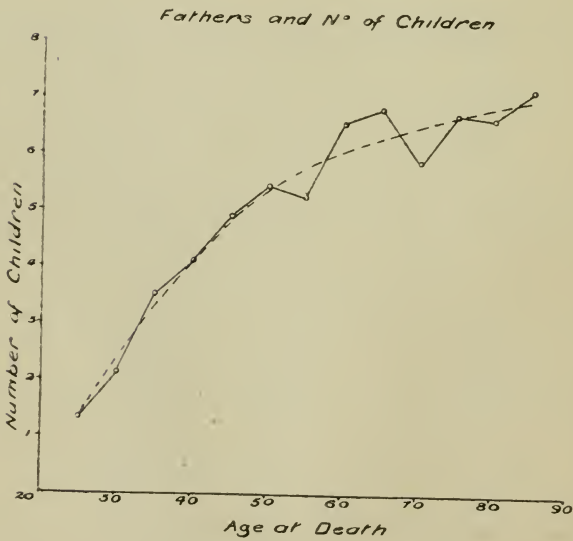

FIG. V.

that of ability in father and son as judged by the Oxford Class Lists. In a recent memoir published by the Galton Eugenics Laboratory he obtains the results given in Table VII. If we allow for an academic selection of intelligence, we reach values singularly close to those obtained for the physical characters. I have added some results of my own, not hitherto published, taken from my Family Record Schedules. To sum up, there appears no doubt that good and bad physique, the liability to and the immunity from disease, the moral characters and the mental temperament, are inherited in man and with much the same intensity.

As a next stage, I point out—if it be needful to do so—that Figures IV and V show that those who live longest, and may be presumed to be the healthiest, leave most offspring.¹ One link still remains unproven—Are these variations subject to selection? Is the death-rate in man a function of his constitution? Or does man fall in his youth or prime or dotage by the purely random bolt of Death? The possibility of solving this last problem occurred to me when studying the inheritance of longevity. If longevity depended only on the physical constitution, we might expect it to be inherited at the same rate as other physical characters. I found it to be inherited always at a *lesser* rate. The difference could only be accounted for by the partly random character of Death's aim. This was the key to measuring the proportion of the selective and non-selective death-rates in man. Table VIII gives you the results. With these results it appears to me that Darwinism is clearly and definitely established for Man.

¹ The data are from the records of the Society of Friends, and show with little doubt an *unrestricted* birth-rate.

It is not so many years ago since a distinguished statesman, speaking within the walls of this University, asserted that 'No man has ever seen natural selection at work'. At that time all the criticism possible seemed, 'Every man who has lived through a hard winter, every man who has examined a mortality table, every man who has studied the history of nations, has *probably* seen natural selection at work.' And thirteen years later I should add: The time has now come for statesmen to inquire whether natural selection is doing its work efficiently; that it applies to man no longer admits of question. Can it possibly be that agencies under the control of the legislator are suspending that Platonic purification of the state which in olden time natural selection worked almost automatically?

TABLE VIII. NATURAL SELECTION IN MAN
PERCENTAGES OF DEATHS DUE TO SELECTIVE DEATH-RATE.
Deduced from Age at Death of Kindred.

<i>From Parental Heredity Data.</i>			<i>From Fraternal Heredity Data.</i>		
<i>Value.</i>	<i>Selected %.</i>	<i>Non-Selected.</i>	<i>Value.</i>	<i>Selected %.</i>	<i>Non-Selected.</i>
.3	67.5	32.5	.4	84.1	15.9
.4	58.4	41.6	.45	79.3	20.7
.45	55.1	44.9	.5	75.2	24.8

Thus between 55 and 75 per cent. of deaths in the case of Man are selective.

This is the next point concerning which Eugenics may have something to tell us. In order that natural selection should be suspended, it is not sufficient to reduce the selective death-rate; it is necessary that the relative fertility of the unfit should be higher than that

of the fit. If the unfit variations leave to any state their heritage of unfitness, what can save that state from degeneracy, what hinder a catastrophe when that state has to prove its only title to seizin in deed of the earth?

TABLE IX. FERTILITY IN PATHOLOGICAL AND NORMAL STOCKS

PATHOLOGICAL.

	<i>Authority.</i>	<i>Nature of Marriage.</i>	<i>Size of Family.</i>
Deaf-Mutes, England . . .	Schuster	Probably completed	6.2
Deaf-Mutes, America . . .	Schuster	" "	6.1
Tuberculous Stock . . .	Pearson	" "	5.7
Albinotic Stock . . .	Pearson	" "	5.9
Insane Stock . . .	Heron	" "	6.0
Edinburgh Degenerates . .	Eugenics Lab.	Incomplete	6.1
London Mentally Defective .	"	"	7.0
Manchester Mentally Defective	"	"	6.3
Criminals	Goring	Completed	6.6

NORMAL.

English Middle Class . . .	Pearson	15 years at least— begun before 35	6.4
Family Records	Pearson	Completed	5.3
English Intellectual Class . .	Pearson	All completed marriages	4.7
Working Class N.S.W. . . .	Powys	Completed	5.3
Danish Professional Class . .	Westergaard	15 years at least	5.2
Danish Working Class . . .	Westergaard	25 years at least	5.3
Edinburgh Normal Artizan . .	Eugenics Lab.	Incomplete	5.9
London Normal Artizan . . .	"	"	5.1
American Graduates	Harvard	Completed?	2.0
English Intellectuals	S. Webb	Said to be completed	1.5

All childless marriages are excluded except in the last two cases. Inclusion of such marriages usually reduces the average by $\frac{1}{2}$ to 1 child.

In Table IX I have placed the fertility of deaf-mute, tuberculous, criminal, and insane stocks, and below them

the fertility of more normal classes in the community. It is at once obvious that degenerate stocks under present social conditions are not short-lived, they live to have more than the normal size of family. Natural selection is largely suspended, but not the inheritance of degeneracy nor the fertility of the unfit. On the contrary, there is more than a suspicion of the suspension of the fertility of the fit. If further evidence be needful, look at the results in Table X for the correlation between all that makes for unfitness and the number of children per married woman under fifty-five. Dr. Heron has indeed shown us that the survival of the unfit is a marked characteristic of modern town life. Every condition which makes for bad nurture as well as bad nature seems to emphasize the birth-rate.

TABLE X. CORRELATION OF BIRTH-RATE MEASURED ON WIVES OF REPRODUCTIVE AGES WITH SOCIAL AND PHYSICAL CHARACTERS OF POPULATION OF LONDON

	FOR 1901 CENSUS.	DAVID HERON.
	<i>Characters Correlated.</i>	<i>Correlation Coefficient.</i>
BIRTH-RATE.		
With males engaged in professions		—·78
With female domestics per 100 females		—·80
With female domestics per 100 families		—·76
With general labourers per 1000 males		+·52
With pawnbrokers and general dealers per 1000 males		+·62
With children employed ages 10-14		+·66
With persons living more than 2 in a room		+·70
With infants under 1 year dying per 1000 births		+·50
With death from phthisis per 100,000		+·59
With total number of paupers per 1000		+·20
With number of lunatic paupers per 1000		+·34
INFANT MORTALITY.		
With children aged 2-4		+·59
" " 5-14		+·54
" " 13-15		+·34
(per 100 wives)		

These last results show that the infantile mortality of the fertile classes does not compensate for their predominant fertility.

As we have found conscientiousness is inherited, so I have little doubt that the criminal tendency descends in stocks. To-day we feed our criminals up, and we feed up the insane, we let both out of the prison or the asylum 'reformed' or 'cured' as the case may be, only after a few months to return to state-supervision, leaving behind them the germs of a new generation of deteriorants. The average number of crimes due to the convicts in His Majesty's Prisons to-day is ten apiece. We cannot reform the criminal, nor cure the insane from the standpoint of heredity, the taint varies not with their moral or mental conduct. These are products of the somatic cells, the disease lies deeper in their germinal constitution. Education for the criminal, fresh air for the tuberculous, rest and food for the neurotic—these are excellent, they may bring control, sound lungs, and sanity to the individual; but they will not save the offspring from the need of like treatment, nor from the danger of collapse when the time of strain comes. They cannot make a nation sound in mind and body, they merely screen degeneracy behind a throng of arrested degenerates. Our highly developed human sympathy will no longer allow us to watch the state purify itself by aid of crude natural selection. We see pain and suffering only to relieve it, without inquiry as to the moral character of the sufferer or as to his national or racial value. And this is right—no man is responsible for his own being; and nature and nurture, over which he had no control, have made him the being he is, good or evil. But here science steps in, crying, 'Let the reprieve be accepted, but next remind the social conscience of its duty to the race. No nation can preserve its efficiency unless dominant fertility be associated with the mentally and

physically fitter stocks. The reprieve is granted, but let there be no heritage if you would build up and preserve a virile and efficient people.'

Here, I hold, we reach the kernel of the truth which the science of Eugenics has at present revealed. The biological factors are dominant in the evolution of mankind; these, and these alone, can throw light on the rise and fall of nations, on racial progress and national degeneracy. In highly civilized states, the growth of the communal feeling—upon which indeed these states depend for their very existence—has not kept step with our knowledge of the laws which govern race development. Consciously or unconsciously we have suspended the racial purgation maintained in less developed communities by natural selection. We return our criminals after penance, our insane and tuberculous after 'recovery', to their old lives; we leave the mentally defective as flotsam on the flood tide of primordial passions. We disregard on every side these two great principles: (*a*) the inheritance of variations, and (*b*) the correlation in heredity of unlike imperfections.¹ The statesman as usual is inert, waiting for the growth of popular opinion. Doctors, we are told, do not believe in heredity. If that be so, they have small idea of the most plentiful harvest yet

¹ We are at present only reaching light on what is a very important principle, namely, that stocks exist which show a general tendency to defect, taking one form in the parent, another in the offspring. Neuroses in the parents become alcoholism or insanity in the offspring; mental defect may be correlated with tuberculosis, albinism with imbecility; and one type of visual defect in the father be found associated with a second in the son. We cannot at present give this fact scientific expression, but it would appear that there is something akin to germinal degeneracy which may show itself in different defects of the same organ or in defects of different organs. The solution, perhaps, lies in a tendency to general defect in the gamete. Even now, I doubt whether it is absolutely unscientific to speak of a general inheritance of degeneracy.

reaped by modern science. The philanthropist looks to hygiene, to education, to general environment, for the preservation of the race. It is the easy path, but it cannot achieve the desired result. These things are needful tools to the efficient, and passable crutches to the halt; but at least on one point Mendelian and Biometrician are in agreement—there is no hope of racial purification in any environment which does not mean selection of the germ.

If I speak strongly, it is because I feel strongly; and the strength of my feeling does not depend on the few facts I have brought before you to-day. It would be possible to paint a lurid picture—and label it Race-Suicide. That is feasible to any one who has seen, even from afar, the nine circles of that dread region which stretches from slum to reformatory, from casual ward and stew to prison, from hospital and sanatorium to asylum and special school; that infernal lake which sends its unregarded rivulets to befoul more fertile social tracts. But the scope of Eugenics is not to stir the social conscience by an exaggerated picture of racial dangers. Those dangers are not wholly recent, if they are increasing in intensity; they are not peculiar to England, as a brief acquaintance with French and German conditions will suffice to show. Nay, even in the New World men are awaking to the peril which high civilizations risk from their treatment of degenerates. What we leave to private effort, the establishment of a Eugenics Laboratory, they propose in the United States to do by a Government Office. The American proposal to establish a laboratory in the Department of the Interior for the study of the abnormal classes and the collection of sociological and

pathological data, has only one, but that a grave defect. No Eugenics Laboratory which confines its attention to the study of the abnormal can fulfil its functions. The positive side is as important as the negative side, and the application of the laws of inheritance to the betterment of the good is as vital as, and far more likely to inspire us with hope of achievement than concentrating our investigations on the excision of the bad.

If we realize the antinomy which Eugenics brings to our notice between high civilization and racial purgation, we ask: How can the dominant fertility of the fitter social stocks be maintained when natural selection has been suspended? I do not think any wise man would be prepared with a full answer to this question to-day. There is no sovereign remedy for degeneracy. Every method is curative which tends to decrease the fertility of the unfit and to emphasize that of the fit. We may find it difficult to define the socially fit, although physique and ability will carry us far; but when we turn to the habitual criminal, the professional tramp, the tuberculous, the insane, the mentally defective, the alcoholic, the diseased from birth or from excess, there can be little doubt of their social unfitness. Here every remedy which tends to separate them from the community, every segregation which reduces their chances of parentage, is worthy of consideration. Strange as it may seem, we are not much beyond the cure suggested by Plato—what is 'euphemistically termed a colony', for the degenerates of each sex. The duty of the man of science is to find out the law, and if possible waken the conscience of his countrymen to its existence. It is the function of the statesman to discover the feasible social remedy which is not at variance with that law.

But, thus far, I have touched on only one side of the problem, the reduction in bad stock. Is not something more to be insisted upon with regard to the increase of good stock? Have we not treated the birth of children as something that concerned the individual and not the state? May not a source of racial greatness lie in a national spirit, like that of Japan, which demands the healthy able child from fitting parents, and looks with sinister eye on those who provide the state with the halt and diseased? I may have overlooked the point, but I have not noticed that this first principle of duty to the race, of national morality, has been fully insisted upon by our ethical writers. I have often heard false pride of ancestry condemned, but I have not seen the true pride of ancestry explained and commended. Surely the man who is conscious that he comes of a stock sound in body, able in mind, tested in achievement, and who knows that, mating with like stock and maintaining himself in health, he will hand down that heritage to his children—surely such a man may have a legitimate pride in ancestry, and is worthy of honourable mention in eugenic records? It seems to me that those who have the welfare of the nation and our racial fitness for the world-struggle at heart, must recognize that this is the ideal which the racial conscience demands of its saner members.

A clean body, a sound if slow mind, a vigorous and healthy stock, a numerous progeny, these factors were largely representative of the typical Englishman of the past; and we see to-day that one and all these characteristics can be defended on scientific grounds; they are the essentials of an imperial race.

As we have found an antinomy between high civiliza-

tion and race purification by natural selection, so there appears to be, a corresponding antagonism between individual comfort and race welfare. It is again the tendency of higher civilization to suspend the more drastic phases of the struggle for existence and the survival of the fitter. The man of education, or made position, says 'the chances of my children are better if I have but few of them', and we reach the startling condition of America, where the classes of ability—the classes which take as their standard an academic education—are not reproducing themselves, their average number of offspring being less than two; we reach the state of affairs which Mr. Sydney Webb tells us is demonstrable in another intellectual circle in this country, an almost childless population with no inheritance of its ability. And against this we have to set the maximum fertility which is reached by the degenerate stocks! Individual welfare and race welfare, are they really as opposed as they appear? Is it true insight to consider that the fewer children the better is their prospect in life? I cannot think that the time has come when the family is no longer an effective social unit. Is the family of two really in a stronger condition to face the world? Is there not mutual help and strength in kinship, and as age comes on must the old and feeble be left to the care of strangers? Eugenically Mr. Powys, in his fine memoir on fertility and duration of life in New South Wales,¹ has shown that in Australia the longest-lived women are neither the mothers of small nor of inordinately large families. They are the mothers of five to six children. Eugenically we have shown that the two or three first-born members of a family are more

¹ *Eiometrika*, vol. iv, pp. 233-92.

FIG. VI

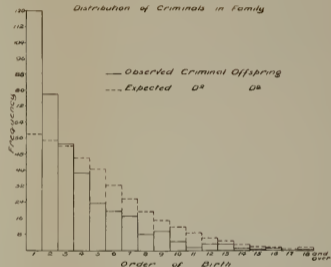
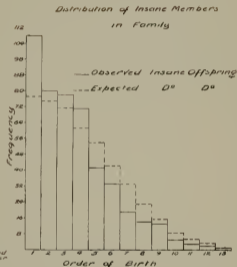
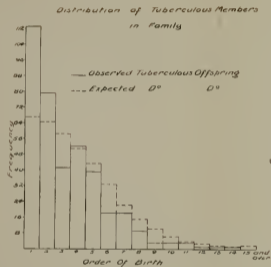

liable to insanity (Heron), tuberculosis (Pearson), criminality (Goring), and mental defect.¹ Fig. VI will illustrate this. The excess of pathological cases among the earlier born is very significant. Economically is it not true that if six degenerates are born to two, and not six, sound men and women, those two will have to do triple work to provide—in prison, asylum, institution, and hospital—for this mass of the incompetent? I am not sure that a strong case could not be made out against the small family even on the basis of individual welfare! But I would rather appeal on this point to race instinct and to the social conscience. The progress of the race inevitably demands a dominant fertility in the fitter stocks. If that principle be not recognized as axiomatic by the mentally and bodily fit themselves, if the statesman does not accept it as a guide in social legislation, then the race will degenerate, until, sinking into barbarism, it may rise again through the toilsome stages of purification by crude natural selection. I am not pessimistic in this attitude. I know that the English people has been aroused to self-consciousness more than once in its history, and I believe that now it can be brought to realize that safety lies in a conscious race-culture. If race feeling can be appealed to by men trained to see the bearing of great biological laws on human growth, then we shall not create a mere passing wave of national emotion conveniently satisfied by the appointment, dead before the report, of a Royal Commission. The time seems upon us when the biological sciences shall begin to do for man what the physical have done for more than a century; when they shall aid him in

¹ It seems to me that here science has a word to say with regard to reform of an hereditary peerage.

completing his mastery of his organic development, as the physical sciences have largely taught him to control his inorganic environment. To bring this about we need above all two factors. First: a knowledge of inheritance, variation, selection, and fertility in man, and the relation of these results to racial efficiency. To this special branch of biology, Francis Galton has given the name of the science of National Eugenics, and in founding the Francis Galton Laboratory for National Eugenics in the University of London he has been the pioneer in asserting that even from the academic standpoint, 'the proper study of mankind is man.' Eighty years ago there were no physical laboratories in the universities of this country, sixty years ago there were no physiological laboratories, thirty years ago there were no engineering laboratories. To-day there is only one laboratory for National Eugenics. I believe that every university twenty years hence will offer its students training in the science that makes for race-efficiency and in the knowledge which alone can make a reality of statecraft. The Eugenics Laboratory then will require no apology, it will be too well recognized a part of university equipment. The second factor which seems to me needful is an altered tone with regard to those phases of our sexual life upon which the health and welfare of the nation as a whole so largely depend. In this matter I think we can learn from the spirit of our youngest allies, the Japanese, and from the practice of our oldest allies, the Jews. With both, race-preservation and race-betterment have assumed the form of a religious cult. And one aim of my lecture to-day is that I may appeal to the younger members of my audience, on whom responsi-

bility for forming opinion will shortly fall, to weigh these things well, for they touch closely our national safety. On the one hand I do not raise an alarmist picture of our coming decadence, nor on the other hand would I leave you without insisting that there is grave occasion for earnest thought. I would raise interest in a new and, I believe, potent branch of science; I would call for a strengthening of racial conscience, and a scientific basis for conduct, as our growing civilization stems natural selection as the purifier of the state. Thus it is that Eugenics passes from Science into Practice, from knowledge to a creed of action. This cannot be expressed better than by Francis Galton's concluding words in his *Eugenics as a Factor of Religion*.

‘Eugenic belief extends the function of philanthropy to future generations, it renders its actions more pervading than hitherto, by dealing with families and societies in their entirety, and it enforces the importance of the marriage covenant by directing serious attention to the probable quality of the future offspring. It sternly forbids all forms of sentimental charity that are harmful to the race, while it eagerly seeks opportunity for acts of personal kindness, as some equivalent to the loss of what it forbids. It brings the tie of kinship into prominence and strongly encourages love and interest in family and race. In brief, Eugenics is a virile creed, full of hopefulness, and appealing to many of the noblest feelings of our nature.’

OXFORD: HORACE HART
PRINTER TO THE UNIVERSITY

UNIVERSITY OF LONDON

DULAU & CO., LTD., 37 SOHO SQUARE, LONDON, W.

EUGENICS LABORATORY LECTURE SERIES.

- I. The Scope and Importance to the State of the Science of National Eugenics. By KARL PEARSON, F.R.S. *Issued.* Third Edition. Price 1s. net.
- II. The Groundwork of Eugenics. By KARL PEARSON, F.R.S. *Issued.* Price 1s. net.
- III. The Relative Strength of Nurture and Nature. By ETHEL M. ELDERTON. *Issued.* Price 1s. net.
- IV. On the Marriage of First Cousins. By ETHEL M. ELDERTON. [*Nearly ready.*]
- V. The Problem of Practical Eugenics. By KARL PEARSON, F.R.S. *Issued.* Price 1s. net.
- VI. Nature and Nurture, the Problem of the Future. By KARL PEARSON, F.R.S. *Issued.* Price 1s. net.
- VII. The Academic Aspect of the Science of National Eugenics. By KARL PEARSON, F.R.S. *Issued.* Price 1s. net.

QUESTIONS OF THE DAY AND OF THE FRAY.

- I. The Influence of Parental Alcoholism on the Physique and Ability of the Offspring. A Reply to the Cambridge Economists. By KARL PEARSON, F.R.S. *Issued.* Price 1s. net.
- II. Mental Defect, Mal-Nutrition, and the Teacher's Appreciation of Intelligence. A Reply to Criticisms of the Memoir on 'The Influence of Defective Physique and Unfavourable Home Environment on the Intelligence of School Children'. By DAVID HERON, D.Sc. *Issued.* Price 1s. net.
- III. An Attempt to correct some of the Misstatements made by Sir VICTOR HORSLEY, F.R.S., F.R.C.S., and MARY D. STURGE, M.D., in their Criticisms of the Galton Laboratory Memoir: 'A First Study of the Influence of Parental Alcoholism', &c. By KARL PEARSON, F.R.S. *Issued.* Price 1s. net.

Issued by the Cambridge University Press:—

Biometrika. A Journal for the Statistical Study of Biological Problems. Founded by W. F. R. WELDON, FRANCIS GALTON, and KARL PEARSON. Edited by KARL PEARSON. Volumes I, II, III, IV, V, VI, and VII complete. Volume VIII, Part I, at press. Subscription price, 30s. net per volume.

THE FRANCIS GALTON LABORATORY FOR NATIONAL EUGENICS

THE Francis Galton Laboratory is issuing in parts, at short intervals, a collection of published and unpublished family pedigrees, illustrating the inheritance in man of mental and physical characters, of disease and of abnormality.

Students of heredity find great difficulty in obtaining easy access to material bearing on human inheritance. The published material is voluminous, scattered over a wide and often very inaccessible journalistic area. The already collected although unpublished material is probably as copious, but no central organ for its rapid publication in a standardized form exists at present. The Eugenics Laboratory alone possesses several hundred pedigrees of family characteristics and diseases which it is desirable to make readily accessible. Many medical men possess similar material, and there is a growing desire among genealogists to pay more attention to family characters and supplement the merely nominal pedigrees current in the past.

For a publication of this kind to be successful at the present time, it should be entirely free from controversial matter. The *Treasury of Human Inheritance* will therefore contain no reference to theoretical opinions. It will give in a standardized form the pedigree of each stock. This will be accompanied by a few pages of text describing the individual members of the stock, giving references to authorities, and, if the material has been published, to the *locus* of original publication. When necessary the characteristic will be illustrated by photography or radiography. In this way it is hoped in the course of a few years to place a large mass of material in the hands of the student of human heredity. It will not cut him off from, but directly guide him to original and fuller sources of information. Further, the *Treasury* will provide students of eugenics and of sociology, medical men, and others, with an organ where their investigations will find ready publication, and where as time goes on a higher and more complete standard of family history than has hitherto been usual can be maintained. It is proposed to issue the *Treasury of Human Inheritance* in quarto parts at about quarterly intervals. Each part will contain about six to ten plates of pedigrees and of such other illustrations as may be needful.

The following parts have already been issued:—

Parts I and II (double part) contain pedigrees of Diabetes Insipidus, Split-Foot, Polydactylism, Brachydactylism, Tuberculosis, Deaf-Mutism, and Legal Ability. Price 14s. *net*.

Part III contains pedigrees of Angioneurotic Oedema, Hermaphroditism, Deaf-Mutism, Insanity, and Commercial Ability. Price 6s. *net*.

Part IV contains pedigrees of Hare-Lip, Cleft Palate, Deaf-Mutism, and Congenital Cataract. Price 10s. *net*.

Parts V and VI (double part) contain pedigrees of Haemophilia. Price 15s. *net*.

Parts VII and VIII containing pedigrees of Dwarfism are at press.

The subscription to each set of four parts will in *future* be 24s., and all communications with regard to pedigree contributions should be sent to: The Editors, *Treasury of Human Inheritance*, Eugenics Laboratory, University College, London, W.C. Subscriptions should be made payable to Miss H. Gertrude Jones, at the above address.

Single parts may be purchased from Messrs. Dulau & Co., Ltd., 37 Soho Square, London, W., either directly or through any bookseller.



3 1158 00915 9830

UNIVERSITY OF CALIFORNIA LIBRARY
Los Angeles

This book is DUE on the last date stamped below.

BIOMED

MAY 7 1985

BIOMED JUN 01 '85

OCT 25 1985

REC'D

BIOMED MAR 13 '88

BIOMED LIB
MAR 13 1988

JAN 10 1991

Biomedical Library

FEB 11 1991

2 WEEK

